

# DESIGN NOTES

## PCMCIA Socket Voltage Switching – Design Note 93

Why Your Portable System Needs SafeSlot™ Protection

Doug La Porte

### Introduction

Most portable systems have built-in PCMCIA sockets as the sole means of expansion. The requirements of the PCMCIA specification have led to some confusion among system designers. This Design Note will attempt to lessen the confusion and highlight other practical system issues.

Host power delivery to the PC card socket flows through two paths: the main  $V_{CC}$  supply pins and the VPP programming pins. Both supplies are switchable to different voltages to accommodate a wide range of card types. The  $V_{CC}$  main card supply must be capable of delivering up to 1A at either 3.3V or 5V. The 1A rating is an absolute maximum derived from the contact rating of 500mA per pin for both  $V_{CC}$  pins and assumes that both pins are in good condition and current is shared equally. One of the most stringent actual current requirements is during hard drive spin-up. Present hard drives require 5V at 600mA to 800mA for a short duration during spin-up. Current draw drops to 300mA to 420mA during read and write operations. A low switch resistance on the 3.3V switch is critical to assure

that the specified 3.0V minimum is maintained. The VPP supply must source 12V at up to 120mA and 3.3V or 5V at lesser currents. The VPP supply is intended solely for flash memory programming. The 120mA current requirement allows writing to flash devices and simultaneously erasing two other parts as required by many flash drives.

The host PCMCIA socket designer also has several other practical aspects of the design to consider. The exposed socket pins are vulnerable to being shorted by foreign objects such as paper clips. In addition the users will attempt to install damaged cards. In short, once in the hands of the consumer, the designer and manufacturer have little control over use and abuse. To ensure a robust system and a satisfied customer, switch protection features such as current limiting and thermal shutdown are a necessity. The nature of the PC cards and portable systems requires the card being powered on and off as needed to conserve power. Many PC cards have large input capaci-

LT, LTC and LT are registered trademarks of Linear Technology Corporation. SafeSlot is a trademark of Linear Technology Corporation.

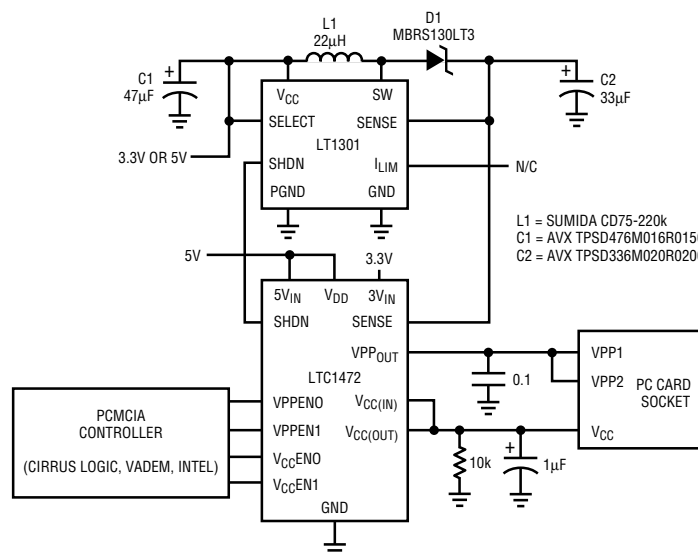

Figure 1. Typical LTC1472 Application with the LT1301 3.3V Boost Regulator

tance and draw over 2W. The power up/down sequencing can put demanding transient requirements on your system power supply. To make the transient response of the system supply manageable, the PCMCIA switch should have break-before-make switching, controlled rise and fall times and current limiting. The slowed rise time coupled with current limiting are critical in controlling the immense in-rush current difficulties seen when charging the large input capacitance of many cards

### LTC<sup>®</sup>1472: Complete V<sub>CC</sub> and VPP PCMCIA Switch Matrix with SafeSlot Protection

The LTC1472 is a complete, fully integrated V<sub>CC</sub> and VPP switch matrix that addresses all of the PCMCIA socket switching needs. Figure 1 shows a typical LTC1472 application used in conjunction with the LT<sup>®</sup>1301 to supply 12V for flash memory programming. The LTC1472's logic inputs allow direct interfacing with both logic high and logic low industry standard controllers without any external glue logic. The LTC1472 is available in the space saving narrow 16-pin SOIC package. The V<sub>CC</sub> switch's R<sub>DS(ON)</sub> is 0.14Ω to support the 1A current requirement. The V<sub>CC</sub> output is switched between 3.3V, 5V and high impedance. The VPP output pin is switched between 0V, V<sub>CC</sub>, 12V and high impedance. Table 1 shows the V<sub>CC</sub> and VPP truth tables.

**Table 1. LTC1472 Truth Table**

V <sub>CC</sub> Switch		
V <sub>CC</sub> EN0	V <sub>CC</sub> EN1	V <sub>CC</sub> (OUT)
0	0	off
1	0	5V
0	1	3.3V
0	1	off

VPP Switch		
VPPEN0	VPPEN1	VPP <sub>OUT</sub>
0	0	0V
0	1	V <sub>CC</sub> (IN)
1	0	VPP <sub>IN</sub>
1	1	Hi-Z

The LTC1472 features SafeSlot protection. The built-in SafeSlot current limiting and thermal shutdown features are vital to ensuring a robust and reliable system. The V<sub>CC</sub> current limit is above 1A to maintain compatibility with all existing cards yet provide protection. The VPP current limit is above 120mA to also maintain compatibility. All switches are break-before-make type with controlled, slowed rise

and fall times for minimal system supply impact. In-rush current, from even the largest card input capacitance, is kept under control by the LTC1472's slowed rise-time switching and current limiting.

The LTC1472 has on-chip charge pumps for switch driving. For this reason, the device does not require a continuous 12V source. Most of the time the LT1301 is in shutdown mode, consuming only 10μA. The LT1301 becomes operational only during flash memory programming. The LTC1472 itself conserves power by going to a low 1μA standby mode when V<sub>CC</sub> and VPP outputs are switched off. The use of the LT1301 is optional. Any suitable 12V supply can be directly connected to the VPP<sub>IN</sub> pin. Caution should be exercised when using a general purpose 12V supply; make certain that it does not have spikes or transients exceeding the flash memory 14V maximum voltage rating and that the regulation is within the 5% flash memory tolerance.

### Conclusion

PCMCIA sockets are the preferred method of expansion in portable systems. As these devices proliferate to less sophisticated users, there will be greater opportunity for abuse. To counter this trend the portable system design must take safeguards to protect the system. The high level of integration, SafeSlot protection features and controlled rise and fall switching make the LTC1472 the ideal solution for portable systems.

Linear Technology has a family of PCMCIA socket voltage control products to suit a broad range of customer's needs. Table 2 lists the present part offerings. For assistance on your specific design needs, call Linear Technology.

**Table 2. Linear Technology's PCMCIA Host Socket Voltage Control Products**

Part Number	Remarks
LT1312	VPP Linear Regulator
LT1313	Dual Slot VPP Linear Regulator
LT1314	Low Cost V <sub>CC</sub> and VPP Switch Matrix
LT1315	Dual Low Cost V <sub>CC</sub> and VPP Switch Matrix
LTC1470	Complete SafeSlot Protected V <sub>CC</sub> Switch Matrix
LTC1471	Dual Complete SafeSlot Protected V <sub>CC</sub> Switch Matrix
LTC1472	Complete SafeSlot Protected V <sub>CC</sub> and Switch Matrix

For literature on our PCMCIA Power Management devices call **1-800-4-LINEAR**. For applications help, call (408) 432-1900, Ext. 361